

DESCRIPTION: Straight type, cast steel body, full bore swing check valve, Stellite coated seat and disc. Raised face flanged.

APPLICATION: Preventing backflow in water, oil and aggressive media systems etc.

STANDARD & DESIGN:

Design Code: API 594
 Inspection Std.: API 598
 End Std.: ASME B16.5
 Face to Face Std.: ASME B16.10
 Flanges drilled: ANSI 150(DN50-DN300)
 Pressure rating: ANSI 150(DN50-DN300)

VARIATIONS: Other materials and dimensions on request.

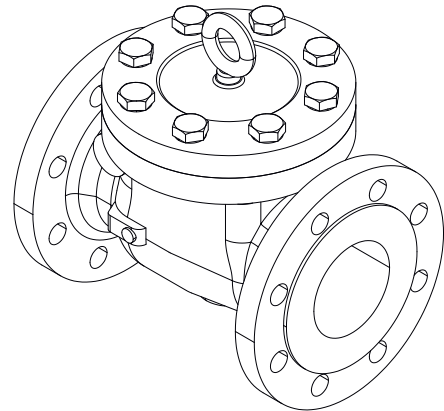

No	Part	Material	Code
1	Body	Cast Steel	ASTM A216-WCB
2	Bonnet	Cast Steel	ASTM A216-WCB
3	Disc	Cast Steel	ASTM A216-WCB
4	Seat	Forged Steel	ASTM A105
5	Hinge	Cast Steel	ASTM A216-WCB
6	Hinge Pin	Stainless Steel	ASTM A276-420
7	Support	Cast Steel	ASTM A216-WCB
8	Gasket	Graphite	-
9	Stud Bolt	Steel	ASTM A193 Gr.B7
10	Nut	Steel	ASTM A194 Gr.2H

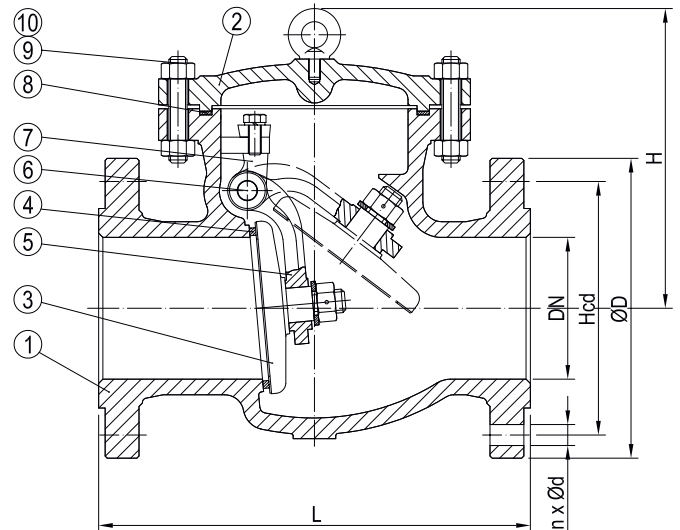

DN	n x ød	Hcd	øD	L	H	Kg
50	4x19	121	150	203	161	17
65	4x19	140	180	216	180	23
80	4x19	152	190	241	190	33
100	8x19	190	230	292	220	44
150	8x22	241	280	356	257	78
200	8x22	298	345	495	292	137
250	12x26	362	405	622	350	207
300	12x26	431	485	699	398	279